

IQAN-XC21

Instruction book

Publ no MSG18-8410-IB/UK
Edition 2022-11-04

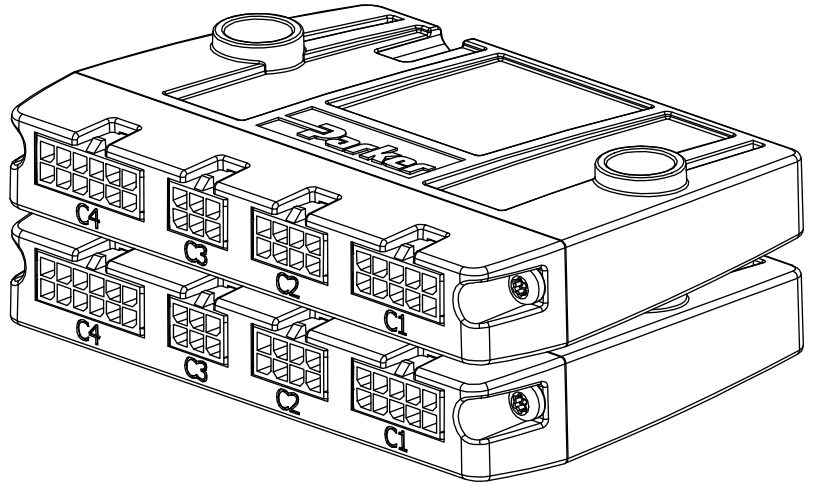

Publication history

The following table provides an overview of the changes made to this document over the course of its publication history.

Revision / date	Description of change
Rev. 001 / 2015-02-18	Added error code 1:1 for DOUT open load.
Rev. 002 / 2018-03-27	Updated Appendix A. Updated document identity to MSG18- (MSDE).
Rev. 003 / 2020-11-19	Updated Appendix A with further details.
Rev. 004 / 2021-05-21	Declaration of conformity updated.
Rev. 005 / 2022-11-04	UKCA Declaration of conformity added. Bus off Blink code added.

Copyright 2020 © Parker-Hannifin Corporation. All rights reserved.

No part of this work may be copied, reproduced, replaced, distributed, published, displayed, modified, or transferred in any form or by any means except with the prior permission of Parker-Hannifin Corporation.

Warning

FAILURE OR IMPROPER SELECTION OR IMPROPER USE OF THE PRODUCTS AND/OR SYSTEMS DESCRIBED HEREIN OR RELATED ITEMS CAN CAUSE DEATH, PERSONAL INJURY AND PROPERTY DAMAGE.

- This document and other information from Parker Hannifin Corporation, its subsidiaries and authorized distributors provide product and/or system options for further investigation by users having technical expertise.
- The user, through its own analysis and testing, is solely responsible for making the final selection of the system and components and assuring that all performance, endurance, maintenance, safety and warning requirements of the application are met. The user must analyze all aspects of the application, follow applicable industry standards, and follow the information concerning the product in the current product catalog and in any other materials provided from Parker or its subsidiaries or authorized distributors.
- To the extent that Parker or its subsidiaries or authorized distributors provide component or system options based upon data or specifications provided by the user, the user is responsible for determining that such data and specifications are suitable and sufficient for all applications and reasonably foreseeable uses of the components or systems.

	Publication history	ii
1	Introduction	1
	Warnings	1
	Overview of relevant documentation	2
2	Precautions	3
	Read This	3
	Design of control system	3
	Start-up, maintenance, and diagnostics	4
3	Product description	5
	IQAN-XC21	5
	I/O overview	5
	CAN related functions	6
	Markings/Approvals	7
4	Safety	9
	Internal diagnostics	9
	CAN-bus interruption	9
	EN ISO 13849-1	9
	Emergency stop	9
5	Mounting	10
	Mounting the module	10
	Assembling of the ID-Tag	10
6	Installation	11
	Connector C1, C2, C3 and C4	11
	Connector C1 pin assignments	12
	Connector C2 pin assignments	12
	Connector C3 pin assignments	12
	Connector C4 pin assignments	13
	Frequency inputs	14
	Connecting sensors to the frequency inputs	14
	Voltage inputs	15
	Connecting sensors to the voltage inputs	15
	Connecting a 2-wire temperature sensor to voltage in	16
	Connecting switches to the voltage inputs using VREF	16
	Connecting switches to the voltage inputs using +BAT	17
	Reference voltage, VREF	18
	Addressing/terminating	19
	Addressing	19
	Terminating	19
	Supply voltage	20
	Emergency stop	20
	Connecting of Supply Voltage	20
	Polarity reversal	20
	Directional frequency inputs	21
	Connecting sensors to the directional frequency inputs	21
	PWM inputs	22
	Connecting PWM sensor	22
	Low-side digital outputs	23
7	Start-up	24
	Start-up procedures	24
	Starting the control system	24

	Prepare for system start	24
	Start the system	24
8	System Diagnostics	25
	Appendix A	26
	IQAN-XC21 Technical Overview	26
	Appendix B	30
	Error codes, messages and actions	30
	LED indicator showing different XC21 modes	30
	Appendix C	31
	Dimensioning of the IQAN-XC21	31

1 Introduction

These instructions are to be used as a reference tool for the vehicle manufacturer's design, production, and service personnel.

The user of these instructions should have basic knowledge in the handling of electronic equipment.

Warnings

Sections marked with a symbol in the left margin, must be read and understood by everyone using the system, carrying out service work, or making changes to hardware and software.

The different symbols used in this manual are defined below.



WARNING

Sections labeled *WARNING* with a caution symbol in the left margin, indicate that a hazardous situation exists. We use warnings, marked with the warning symbol, in two ways.

- As a strong recommendation about work practices when using the product in the machine (e.g. routines when updating an application). This use is common to the term 'hazardous situation', that a person is exposed to a hazard.
- As a way of pointing out important information for the machine designer that in some way relates to safety. This includes the design of the physical machine, and also the application program being developed for the control system.

Not all document sections that contain information about safety are marked with a warning symbol (there would be warnings everywhere). Failure to comply with the recommendations can cause unintentional, and unexpected behavior of the control system. This can potentially cause death, serious injury or property damage.



NOTICE

Sections labeled *NOTICE* with a notice symbol in the left margin, indicate there is important information about the product. Ignoring this could result in less than optimal performance, or damage to the product.

Contact the manufacturer if there is anything you are not sure about or if you have any questions regarding the product and its handling or maintenance.

The term "manufacturer" refers to Parker Hannifin Corporation.

Overview of relevant documentation

The following publications are relevant for users of this product.

The main documentation contains information that is not found elsewhere.

The additional documentation contains product information in a compact format, for details on the information found in those documents, consult this manual.

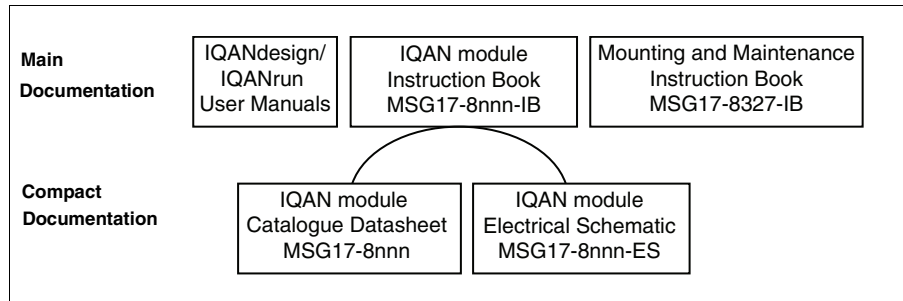

The IQAN module documentation system.

2 Precautions

Work on the hydraulics control electronics may only be carried out by trained personnel who are well-acquainted with the control system, the machine and its safety regulations.



WARNING

Make sure that you have sufficient knowledge before designing, modifying or servicing the control system.

Read the relevant sections of this document before conducting any work on the control system.



WARNING

This product is not field repairable.



NOTICE

As much as possible of the welding work on the chassis should be done before the installation of the system. If welding has to be done afterwards, the electrical connections on the system must be disconnected from other equipment. The negative cable must always be disconnected from the battery before disconnecting the positive cable. The ground wire of the welder shall be positioned as close as possible to the place of the welding. The cables on the welding unit shall never be placed near the electrical wires of the control system.

Read This

Design of control system



WARNING

Risk of injury may be introduced by design of control system!

This product is designed to control hydraulic outputs. The control application must be designed using basic safety principles so that unintentional movement is avoided.

The machine must be equipped with an emergency stop that stops all movement. Please refer to section "Supply voltage".

Before you start

Read this document.

Read the IQANdesign software user manual section on 'application safety'.

Start-up, maintenance, and diagnostics

For all personnel carrying out installation, commissioning, maintenance or troubleshooting.



WARNING

Work on the hydraulics control electronics may only be carried out by trained personnel who are well-acquainted with the control system, the machine and its safety regulations.

Before you start,

Read section "Start-up".

Additional information for service

Mounting and maintenance instruction book.

Additional information for diagnosing the system

Read section "System diagnostics", and see "Appendix B", in this document.

Use the IQANrun software user manual as a reference.

3 Product description

IQAN-XC21

The IQAN-XC21 is a stackable, flexible expansion module designed as a signal input module for use in cab, using 12/24 Vdc power supply.

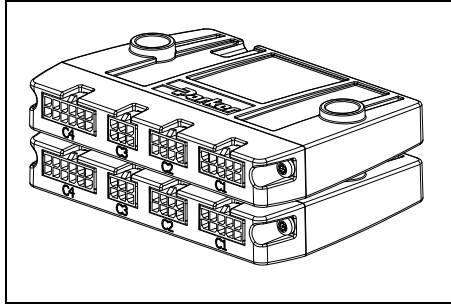

Two IQAN-XC21 modules

I/O overview

Voltage inputs

The IQAN-XC21 module has eight (8) *voltage inputs* VIN-A thru VIN-H for connection of 0-5 Vdc signals. The inputs are multi-purpose and may be configured as *digital inputs* DIN-M thru DIN-T. *Voltage inputs* and *digital inputs* share positions, see below.

(8) Voltage inputs VIN-A, VIN-B, VIN-C.....VIN-H

or

(8) Digital inputs DIN-M, DIN-N.....DIN-T use positions VIN-A thru VIN-H

Digital inputs and outputs

The XC21 module has twelve (12) *digital inputs* DIN-A thru DIN-L for connection of on/off signals. Most of these inputs are multi purpose and can be configured in other ways.

The eight (8) *digital inputs* DIN-A thru DIN-H can be configured as *low-side digital outputs* DOUT-A thru DOUT-H.

The ten (10) inputs DIN-J, DIN-K and DIN-A thru DIN-H can be configured as *frequency inputs* FIN-A thru FIN-J or *pulse count inputs* PCNT-A thru PCNT-J.

The three (3) inputs DIN-A thru DIN-C can be configured as *pulse width modulation inputs* PWMIN-A thru PWMIN-C.

The two (2) inputs DIN-K and DIN-L can be configured as *quadrature input* for measuring directional frequency input DFIN-A or directional pulse count DPCNT-A. *Digital inputs, digital outputs, frequency inputs, pulse count inputs, pulse width modulation inputs* and *quadrature inputs* share positions, see below.

(12) digital inputs DIN-A thru DIN-L

or

(4) digital inputs DIN-I thru DIN-L and (8) low-side digital outputs DOUT-A thru DOUT-H (use positions DIN-A thru DIN-H)

or

(2) digital inputs DIN-I and DIN-L and (10) frequency or pulse count inputs FIN/PCNT-A thru FIN/PCNT-J (use positions DIN-A thru DIN-H, DIN-J and DIN-K)

or

(7) digital inputs DIN-D thru DIN-J and (3) pulse width modulation inputs PWMIN-A thru PWMIN-C (use positions DIN-A thru DIN-C) and (1) directional frequency or pulse count input DFIN/DPCNT-A (use positions DIN-K and DIN-L)

CAN related functions

The master uses the CAN-bus (CAN = Controller Area Network) to communicate with the modules. The CAN-bus is a robust communication protocol that is widely used and well proven within the automotive industry.

Markings/Approvals

The markings/approvals reflect the state of the products at the time of publishing.



Declaration of Conformity

We: Parker Hannifin Manufacturing Sweden AB
Mobile Hydraulic Systems Division Europe

Located at: Mölnlycke Fabriker 14
S-435 35 Mölnlycke, SWEDEN
Tel. +46 31 750 44 00

Declare that the products identified herein comply with the essential requirements of the following EU directives:

2014/30/EU **EU EMC Directive**
2011/65/EU **EU RoHS II Directive**

Harmonized standards:

ISO 14982:2009	Agricultural and forestry machines - Electromagnetic compatibility - Test methods and acceptance criteria
ISO 13766-1:2018	Earth-moving and building construction machinery - Electromagnetic compatibility (EMC) of machines with internal electrical power supply - Part 1: General EMC requirements under typical electromagnetic environmental conditions
EN 50581:2012	Technical documentation for the assessment of electrical and electronic products with respect to the restriction of hazardous substances

Trade Name: Electrohydraulic Control Systems

Products: **IQAN-XC21**

Signature of responsible party:

A handwritten signature in black ink, appearing to read 'Håkan Jisland', written over a light blue horizontal line.

Printed name of responsible party: Håkan Jisland
Position of responsible party: Business Unit Manager

Executed on May 12th 2021, at Mölnlycke, Sweden



Declaration of Conformity

We: Parker Hannifin Manufacturing Sweden AB

Located at: Bruksgatan 20
S-435 35 Mölnlycke, SWEDEN
Tel. +46 31 750 44 00

Declare that the products identified herein comply with the essential requirements of the following UK regulations:

S.I. 2016 No. 1091 Electromagnetic Compatibility Regulations 2016

S.I. 2012 No. 3032 The Restriction of the Use of Certain Hazardous Substances in Electrical and Electronic Equipment Regulations 2012

Designated standards:

ISO 14982:2009 Agricultural and forestry machines - Electromagnetic compatibility - Test methods and acceptance criteria

ISO 13766-1:2018 Earth-moving and building construction machinery - Electromagnetic compatibility (EMC) of machines with internal electrical power supply - Part 1: General EMC requirements under typical electromagnetic environmental conditions

EN 50581:2012 Technical documentation for the assessment of electrical and electronic products with respect to the restriction of hazardous substances

Trade Name: Electrohydraulic Control Systems

Products: IQAN-XC21

Signature of responsible party:

A handwritten signature in blue ink, appearing to read "Håkan Jisland".

Printed name of responsible party: Håkan Jisland

Position of responsible party: Business Unit Manager

Executed on November 3rd 2022, at Mölnlycke, Sweden

4 Safety

Internal diagnostics

The module performs a number of self-checks that improve safety. Checks include monitoring of voltage supplies, checksums on memory and a watchdog that monitors software execution. The module is using a real time operating system which supervises software execution.

If a critical error is detected, the module is stopped, with CAN-bus and outputs off.

CAN-bus interruption

The IQAN modules communicate on a CAN-bus. Both the master module and expansion modules check for any interruptions in CAN-bus communication. If an error occurs the master will use zero or an application defined error value for the module inputs, and the module outputs will be off.

The error will be presented on the master/display module, if there is one, and with a related blink code on the IQAN module status LEDs, see Appendix B.

EN ISO 13849-1

The IQAN-XC21 is not designed as a safety component with a PL rating. To make it possible for system integrator to use XC21 inputs as a design element, component reliability data is provided.

The MTTFd values specified in Appendix A are calculated based on FMEDA, for additional details on failure mode effect and failure mode distribution, please contact Parker.

Emergency stop



WARNING

Risk of injury!

The emergency stop must disconnect the power supply to the module; do not connect the emergency stop as a signal input only.

The emergency stop must be installed so that the risk of reverse feed of the module is avoided, see section "Supply voltage".

5 Mounting

Mounting the module

IQAN-XC21 is designed as a in cab module and is meant to be mounted in a protected environment. The housing is designed for stacking multiple modules, providing a high density of I/O in a small footprint.

The IQAN module should be mounted according to the following instructions:

- Locate the module eliminating the risk for the cabling to be folded, crushed or damaged in any way. Ensure the cabling cannot pull, twist or induce sideload on the connector.
- Locate the module so that severe physical impact is avoided, e.g impact from falling objects or the module being used as a step.
- Locate the module so that air can circulate to eliminate excess heat. Ensure that no external heat, e.g. from the engine or heater, is transferred to the module.
- Locate the module so that the LEDs are visible.



NOTICE

The IQAN module must not be placed in any marine related or similar continuously damp, salt-spray environment without external protection.

Assembling of the ID-Tag

The ID-Tag will be placed in the connector in order to address/ terminate the module. Any IQAN ID-Tags with AMP or Deutsch terminals may be used by replacing the contacts with the correct type, see section "Installation". All IQAN expansion modules require an ID-tag, refer to section "Addressing/terminating".

6 Installation

Connector C1, C2, C3 and C4

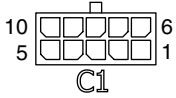
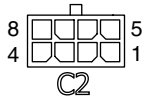
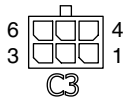
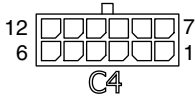
Connector kit	Parker N/A	
Mating connector	Molex no. 43025-1000	C1
Pin type (loose)	Molex no. 43030-0008	
Pin type (reel)	Molex no. 43030-0002	
Plating	Selective gold 0.38µm (there is also a 0.76µm version)	
Recommended cable	ø1.85mm max (AWG 20, 22, 24)	
Mating connector	Molex no. 43025-0800	C2
Pin type (loose)	Molex no. 43030-0008	
Pin type (reel)	Molex no. 43030-0002	
Plating	Selective gold 0.38µm (there is also a 0.76µm version)	
Recommended cable	ø1.85mm max (AWG 20, 22, 24)	
Mating connector	Molex no. 43025-0600	C3
Pin type (loose)	Molex no. 43030-0008	
Pin type (reel)	Molex no. 43030-0002	
Plating	Selective gold 0.38µm (there is also a 0.76µm version)	
Recommended cable	ø1.85mm max (AWG 20, 22, 24)	
Mating connector	Molex no. 43025-1200	C4
Pin type (loose)	Molex no. 43030-0008	
Pin type (reel)	Molex no. 43030-0002	
Plating	Selective gold 0.38µm (there is also a 0.76µm version)	
Recommended cable	ø1.85mm max (AWG 20, 22, 24)	



NOTICE

Tin plated contacts must NOT be used, the header has gold plated terminals and this must be matched on the receptacle to fulfill all environmental requirements.

Connector C1 pin assignments

Pin No.	Function	Remark
1	-VBAT	Dual pin for -VBAT daisy chain, max 5A
2	-VBAT	Dual pin for -VBAT daisy chain, max 5A
3	CANL-A	
4	CANL-A	
5	ADDR-L	
6	+VBAT	Dual pin for +VBAT daisy chain, max 5A
7	+VBAT	Dual pin for +VBAT daisy chain, max 5A
8	CANH-A	
9	CANH-A	
10	ADDR-H	

Connector C2 pin assignments

Pin No.	Function	Alt. Function	Remark
1	-VREF-A		
2	VIN-A	DIN-M	LC6-Xp
3	-VREF-A		
4	VIN-C	DIN-O	LC6-Yp
5	+VREF-A (+5V)		Max 70 mA shared on pin 5 and 7
6	VIN-B	DIN-N	LC6-Xs
7	+VREF-A (+5V)		Max 70 mA shared on pin 5 and 7
8	VIN-D	DIN-P	LC6-Ys

Connector C3 pin assignments

Pin No.	Function	Alt. Function	Remark
1	-VREF-B		
2	VIN-E	DIN-Q	Lever signal Z1p
3	VIN-G	DIN-S	Lever signal Z2p
4	+VREF-B (+5V)		Max 70 mA
5	VIN-F	DIN-R	Lever signal Z1s
6	VIN-H	DIN-T	Lever signal Z2s

Connector C4 pin assignments

Pin No.	Function	Alt. Function	Alt. Function	Alt. Function	Alt. Function
1	DIN-A	DOUT-A	FIN-C	PCNT-C	PWMIN-A
2	DIN-B	DOUT-B	FIN-D	PCNT-D	PWMIN-B
3	DIN-C	DOUT-C	FIN-E	PCNT-E	PWMIN-C
4	DIN-D	DOUT-D	FIN-F	PCNT-F	
5	DIN-E	DOUT-E	FIN-G	PCNT-G	
6	DIN-F	DOUT-F	FIN-H	PCNT-H	
7	DIN-G	DOUT-G	FIN-I	PCNT-I	
8	DIN-H	DOUT-H	FIN-J	PCNT-J	
9	DIN-I				
10	DIN-J		FIN-A	PCNT-A	
11	DIN-K	+DPCNT-A	FIN-B	PCNT-B	+DFIN-A
12	DIN-L	-DPCNT-A			-DFIN-A

Frequency inputs

Connecting sensors to the frequency inputs

Frequency inputs can operate in 2 modes. *Speed* which is frequency and *position* which is a pulse count. For the frequency ranges and trigger levels, see Appendix A.

Simple frequency sensor

The positive terminal of the frequency sensor is connected to the +VREF and the negative terminal to the -VREF respectively. The sensor signal is connected to the FIN position.

If the current consumption for the sensor exceeds the maximum load for the VREF, the sensor could be connected to the +BAT/-BAT positions.

EXAMPLE

Connect the positive and negative terminals of the frequency sensor to +VREF, and -VREF, respectively. Then connect the sensor signal to FIN-X.

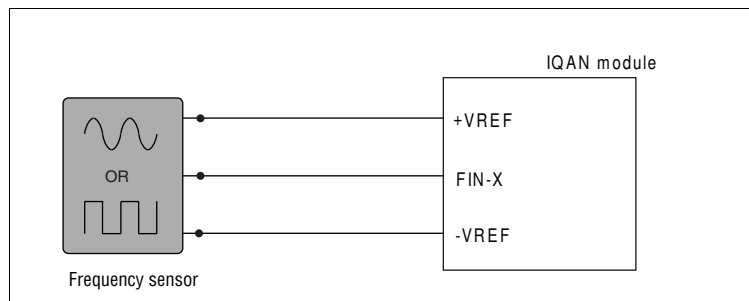

Connecting of frequency sensor.



NOTICE

The negative terminal of the sensor must not be connected to the chassis. Maximum load for VREF position, see Appendix A.

Voltage inputs

Connecting sensors to the voltage inputs

The sensor signal range must be 0-5 Vdc. To detect signal errors such as short circuits or interruptions the active signal range be within 0.5-4.5 Vdc.

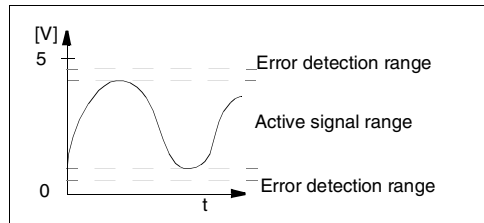

Active signal range.

The current consumption related to the voltage input is negligible.

The positive terminal of the sensor is connected to the +VREF position and the corresponding negative terminal to the -VREF position. The sensor signal is connected to appropriate VIN position.

EXAMPLE

Connect the positive and negative terminals of the position sensor to +VREF, and -VREF, respectively. Then connect the sensor signal to VIN-X.

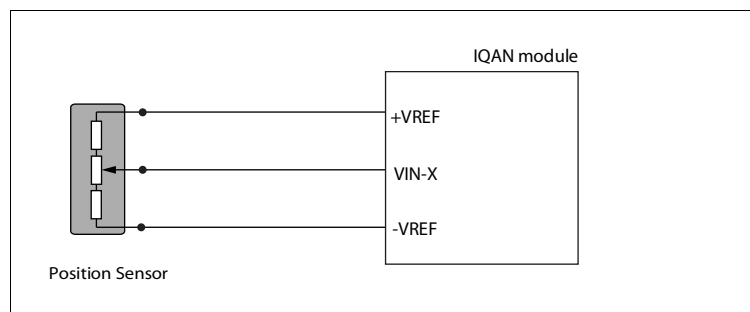

Connecting VREF and sensor signal VIN-X.



NOTICE

The negative terminal of the sensor must not be connected to the chassis.
Maximum load for VREF position: see Appendix A.

Connecting other 3 wire sensors

The same type of connection shown for potentiometers is used for other 3 wire sensors supplied with power from the regulated 5VDC supply, VREF. This includes active temperature sensor IQAN-ST, pressure sensor IQAN-SP and Hall-effect levers IQAN-LST or IQAN-LSL.

Connecting a 2-wire temperature sensor to voltage in

When you connect a PTC (positive temperature coefficient) temperature sensor you may need to use a pull up resistor on the input signal. Please check the technical data for your specific temperature sensor.

EXAMPLE

Connect the negative terminal of the temperature sensor to -VREF, and the signal to VIN-X. The pull up resistor will be connected between VIN-X, and +VREF.

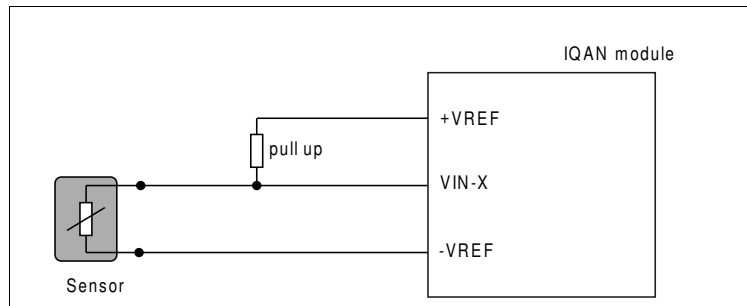

Connecting -VREF and temperature sensor signal VIN-X.

The pull up resistor value for a $R_{25}=2000\Omega$, PTC sensor is 4,7 K Ω .

Connecting switches to the voltage inputs using VREF

Switches could be connected to the voltage inputs, to create a digital on/off signal. The switches should be connected to +VREF and VIN/DIN respectively for 5V signal. The current consumption for the input is negligible.

EXAMPLE

Connect the positive and negative terminals of the switch to +VREF, and VIN-X, respectively.

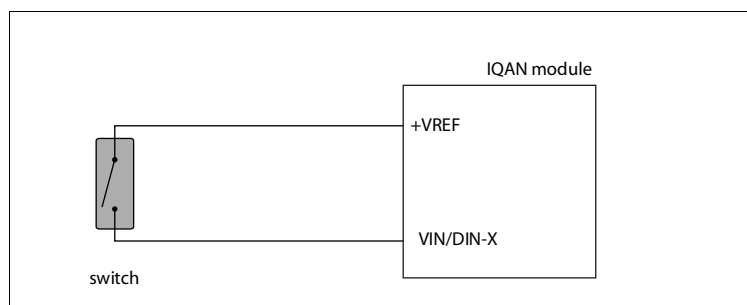

Connecting a switch to VIN-X and VREF.



NOTICE

Maximum load for VREF position, see "Appendix A".

Connecting switches to the voltage inputs using +BAT

It is recommended to connect system voltage +BAT to the input through a switch in order to reserve 5Vdc VREF for sensors and potentiometers.

EXAMPLE

Connect the positive and negative terminals of the switch to supply or the unit's +BAT, and DIN-X, respectively.

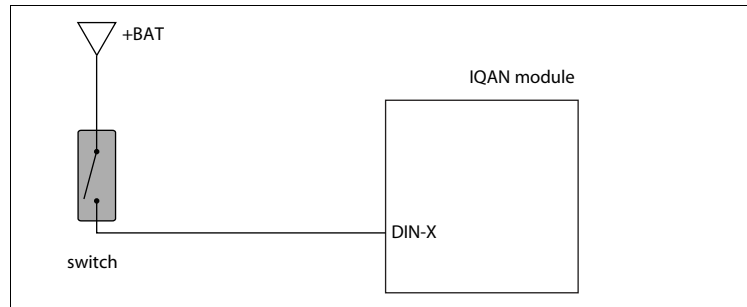

Connecting a switch to DIN-X and +BAT.

Reference voltage, $VREF$

The IQAN module is internally equipped with a voltage regulator to generate the reference voltage $VREF$. The standard reference voltage will feed different kinds of sensors and potentiometers.

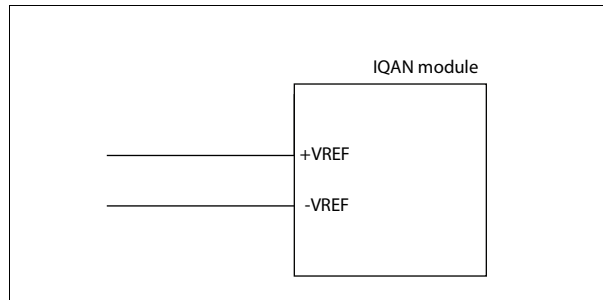

$VREF$ positions.



NOTICE

It is strongly recommended to use the module's $-VREF$ and $+VREF$ to all sensors and potentiometers that are connected to the module inputs. This will reduce bad measurement based on potential fault (i.e. different ground points for other supplies in relation to the IQAN module ground, -BAT).

Maximum load for the $VREF$, see "Appendix A".

Addressing/terminating

Addressing

Each IQAN expansion module will have a specific address, enabling the *master module* to communicate with the modules through the CAN-bus. When operating, the system distinguishes between different modules by first verifying the module type and secondly, through the modules having unique addresses.

EXAMPLE

If having an expansion module with address 0, the system will denote this one as [module type]-A0, The letter "A" in the example refers to CAN-bus A.

The maximum number of similar modules in a system is four or eight depending on the master module, denoted in the first case as addresses 0, 1, 2, 3 respectively. In order to assign any IQAN module a unique CAN-address, an *ID-Tag* will have to be connected to the positions ADDR-H and ADDR-L.

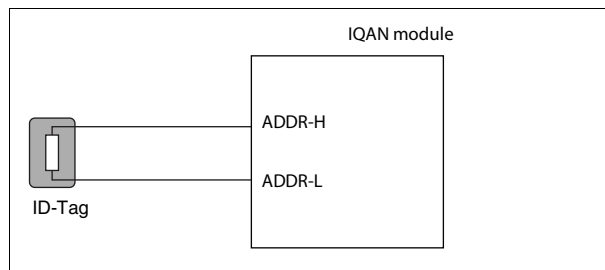

Connecting of Id-Tag.

Terminating

To eliminate interference in the communications through the CAN-bus, the CAN-bus must be terminated at both ends. By default, if no ID-tag is installed in an IQAN master, it will be terminated internally to be the Bus master and will have no special configuration.

When an IQAN expansion module is located at the end of the CAN-bus, then you would use an ID-tag having a combined addressing and terminating function. This is denoted with a "T" for terminating, after the appropriate address such as; 0T, 1T, 2T... etc. In the application, the same address value as the non-terminated ID-Tag with equivalent number will be transferred to the application.

Selecting appropriate ID-Tag

- Check the address number of the module assigned in the application.
- If the module is located at the end of the CAN-bus, then select the appropriate *ID-Tag* denoted with a "T".



NOTICE

The CAN-bus must not be terminated at the module using an external regular terminating resistor, due to the fact that terminating is made from within the module by default or in conjunction with the *ID-Tag*.

Supply voltage

Before any installation of the IQAN system can take place, make sure the ignition lock is turned off and the battery is disconnected.

Emergency stop

Make sure an *Emergency Stop* disconnecting the power supply, is easily accessible at any time. The figure below shows how to connect the emergency stop.

Connecting of Supply Voltage

The supply voltage, should be within the operating interval, see Appendix A. Connect the supply voltage to +BAT and -BAT. Protect the module by using a fuse. For recommended fuse level, see Appendix A.

RTC supply

IQAN master modules have a clock that is used for date/time stamping when logging data. The *real time clock*, +RTC, requires a separate positive power connection.

Connect the supply voltage to +RTC through a 1.5K ohm resistor. The resistor should be as close to the battery as possible for safety.

IQAN expansion modules do not have +RTC.



WARNING

Risk of injury!

To reduce the risk for uncontrolled supply of an IQAN master module, i.e., a short circuit between the +RTC cable and +BAT, a resistor must be connected between the battery and the +RTC input. This is important as this line is not controlled by an emergency stop.

The resistor should be placed close to the battery, as the 'protected' part is the cable between the resistor and the unit.

This will prevent the +RTC wire from powering up the unit if shorted to +BAT.

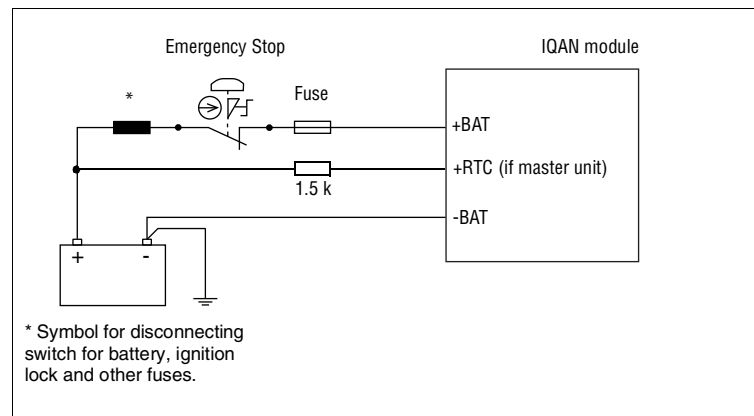

Connecting the emergency stop and voltage supply.



NOTICE

Do not use the chassis as the negative terminal.

Polarity reversal

The module is protected against power supply polarity reversal and over-voltage, provided an external fuse is being used.

If this fuse is not used, polarity reversal can damage the unit.

Directional frequency inputs

Connecting sensors to the directional frequency inputs

Directional frequency inputs can operate in 2 modes. *Speed* which is frequency and *position* which is a pulse count. For the frequency ranges and trigger levels, see Appendix A.

Simple directional frequency sensor

The positive terminal of the directional frequency sensor is connected to the +VREF and the negative terminal to the -VREF respectively. The sensor signals are connected to the DFIN+ and DFIN- positions..

EXAMPLE

Connect the positive and negative terminals of the frequency sensor to +VREF and -VREF, respectively. Then connect the sensor signals to DFIN+ and DFIN-.

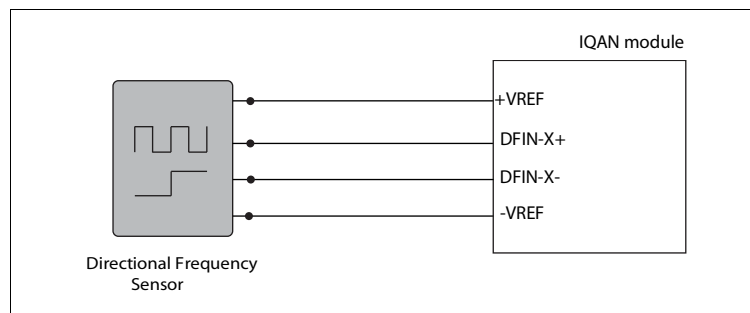

Connecting of directional frequency sensor to DFIN+ and DFIN-.



NOTICE

The negative terminal of the sensor must not be connected to the chassis. Maximum load for VREF position, see Appendix A.

PWM inputs

Connecting PWM sensor

The positive terminal of the PWM sensor is connected to the +VREF and the negative terminal to the -VREF respectively. The sensor signal is connected to a PWMIN position.

If the current consumption for the sensor exceeds the maximum load for the VREF, the sensor could be connected to the +BAT/-BAT positions.

For frequency range and minimum pulse width, see Appendix A.

EXAMPLE

Connect the positive and negative terminals of the PWM sensor to +VREF, and -VREF, respectively. Then connect the sensor signal to PWMIN-x.

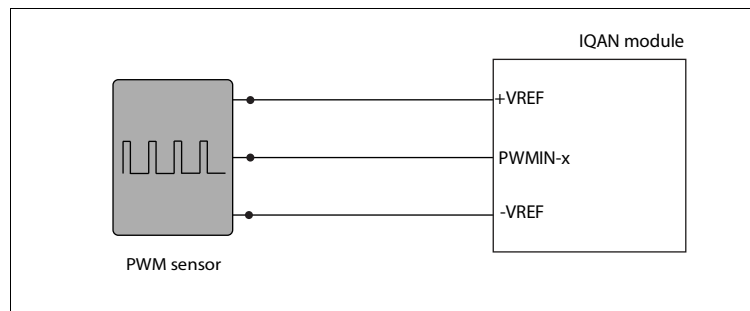

Connecting of PWM sensor.



NOTICE

The negative terminal of the sensor must not be connected to the chassis. Maximum load for VREF position, see Appendix A.

Low-side digital outputs

The low-side digital outputs are designed to drive small loads, e.g. lamps and buzzers. Low-side digital outputs work by grounding a signal through the module. See Appendix A for maximum loads per output.

EXAMPLE

Connect the lamp to the low-side digital outputs using a DOUT(LS)-X position, and the +BAT, as supply.

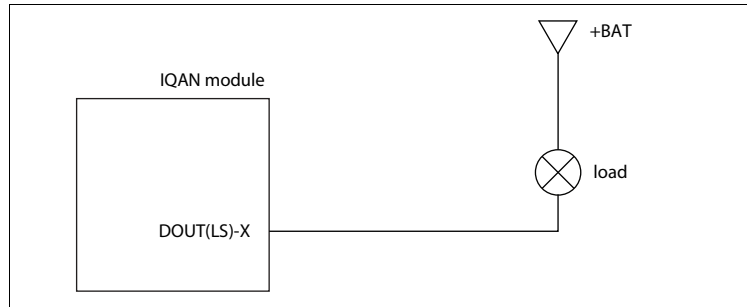

Connecting a switch to DOUT(LS)-X and +BAT.

7 Start-up

Start-up procedures

This chapter contains instructions for action to be taken in connection with the initial start.



WARNING

Risk of injury!

If the control system is not fitted properly, the machine could move uncontrollably. The machine's engine shall not be started before the control system is completely fitted and its signals are verified.

Starting the control system

Start the control system as follows:

- Prior to start, all modules and cables are to be fitted correctly.
- Check fuses, i.e. make sure that the supply voltage to the modules is equipped with the correct fuse.
- Make sure that connections for supply voltage and return lines are correct in the cable's conductor joint.
- Make sure an emergency stop is installed.
The emergency stop should disconnect the supply voltage to all modules. Alternatively, the emergency stop may also shut off the diesel engine or a dump valve, and with that, depressurize the hydraulic system.

Prepare for system start



WARNING

Make sure no one is in dangerous proximity to the vehicle to avoid injuries when it starts.

Prepare for the initial system start as follows:

- The engine for the hydraulic system's pump shall be in off position.
- Make sure that all connectors are properly connected.
- Turn on the control system.
- Make sure that voltage is being supplied to all modules; the power/status diode shall be illuminated on all modules. Also, make sure that the master is in contact with all modules by reading the master's display.
- Make sure the emergency stop is functioning properly.

Start the system

Start the system as follows:

- Start the engine for the hydraulic system's pump, assuming that the above mentioned inspections have been carried out and shown correct values.

Calibrate and adjust input and output signals according to the instructions related to the master menu system and check each and every output function carefully.

8 System Diagnostics

The yellow blinking LED on the top of the module indicates normal status. If there is an error detected, the IQAN module will indicate *error status* through the red blinking LED.

This gives an immediate diagnosis as to the nature of the error that has occurred.

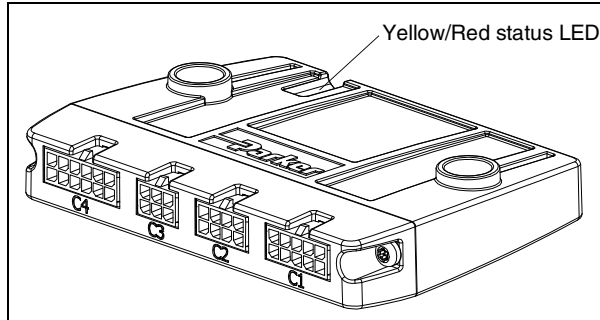

The location of the LED indicators on the IQAN module.

The LED indicates power on. The yellow/red LED, will be blinking red when an error has been detected. For further information about the error messages, see Appendix B.

Appendix A

IQAN-XC21 Technical Overview

System

Operating temperature	-30 to 70 °C
Absolute maximum temperature	-40 to 85 °C
Storage temperature	-40 to 85 °C
Voltage supply	9 to 32 V
Power on threshold	typical 6.7 V
Over voltage on any pin	36 V (with respect to -BAT)
Reverse polarity protection on +BAT	with external 5 A fuse
Current supply V _{BAT} = 14V V _{BAT} = 28V	30 mA 20 mA
Weight	65 g
MTTFd	236 [y]

Environment ratings

Climate environment Enclosure, water & dust protection Salt mist Damp heat cyclic Damp heat steady state Heat, operation Heat, storage Cold Change of temperature	IEC 60529:2001, IP32 IEC 60068-2-52:1996 Kb, 72 h IEC 60068-2-30:2005 Db, +55°C, 95% RH, 6 cycles IEC 60068-2-78:2001 Cab, +40°C, 93% RH, 21 days IEC 60068-2-2:2007 Bb, +70°C, 72 hours IEC 60068-2-2:2007 Bb, +85°C, 72 hours IEC 60068-2-1:1993 Ab, -30°C, 16 hours IEC 60068-2-14:1984 Nb, -30°C to +55°C, 10 x 8 hours
Mechanical environment Random vibration Bumb	IEC 60068-2-64: 2008 Fh, 15 - 1000 Hz, 7.1 Grms, 3 x 10 h IEC 60068-2-27:2008 Ea, 40 g, 6 ms, 1000 * 6 dir
EMC Radiated emission Conducted emission Conducted susceptibility Radiated susceptibility Conducted transients susceptibility ESD, Operation ESD, Handling	ISO 13766-1:2018/ISO 14982:2009 EN 55025:2003, 0.15-108 MHz, Class 1 ISO 11452-4:2011, 1 - 200 MHz, 1 kHz, 80% AM, 150 mA ISO 11452-2:2004, 20-2000 MHz, 1kHz, 80% AM, 60-100 V/m ISO 11452-2:2004, 800-2000 MHz, PM 577 us / 4.6 ms, 60 V/m ISO 7637-2:2004, Pulse 1, 2a, 2b, 3a, 3b, Level 3 ISO 16750-2:2012, Starting profile:level 4, Load dump:level 3 ISO 7637-3:2007, Level 3 ISO 10605:2008, 8 kV (contact), 15 kV (air) ISO 10605:2008, 8 kV (contact)

Sensor supply - VREF

Number of VREF	2
Output voltage	5 V \pm 150 mV, -30 to 70 °C
Output voltage temperature drift	0.50 mV/°C
Maximum load current	70 mA
Protection	over load, SCB, SCG
Diagnostics	over/under voltage
Under/over voltage threshold	\pm 70 mV from nominal value

Signal input - VIN

Number of VIN	8 (configuration may reduce number)
VIN full scale	5000 mV \pm 100 mV
VIN resolution	12 bits = 1.22 mV
Input impedance	36 kohm pull-down in parallel with 10 nF
Accuracy with external sensor supply with VREF sensor supply	\pm (1% + 10mV) \pm (0.5% + 10mV)
Sample rate	same as system cycle time T _{SC}
Maximum continuous voltage	32V
Protection	SCB, SCG
Diagnostics	defined in application

Signal input - DIN

Number of DIN	12 (configuration may reduce number)
Logic levels low high	<1 V >4 V
hysteresis	>250 mV
Input impedance	6.8 kohm in parallel with 10 nF
Sample rate	Same as system cycle time T _{SC}
Maximum continuous voltage	32 V
Diagnostics	defined in application

Signal input - FIN/PCNT

Number of FIN	10 (configuration may reduce number)
Frequency range FIN-A to B FIN-C to J	1 to 20.000 Hz (>20 Hz in Fast response) 1 to 20.000 Hz 1 to 4000 Hz
Minimum pulse width FIN-A to B FIN-C to J	50 us 125 us
Step response	400 ms, 10 to 90% step
Logic levels low high	<1 V >4 V
hysteresis	>250 mV
Input impedance	6.8 kohm in parallel with 10 nF
Maximum continuous voltage	32 V
Diagnostics	defined in application

Signal input - DPCNT/DFIN

Number of DPCNT	1 (configuration may reduce number)
Frequency range	0 to 20.000 Hz
Minimum pulse width	50 us
Logic levels low high	<1 V >4 V
hysteresis	>250 mV
Input impedance	6.8 kohm in parallel with 10 nF
Maximum continuous voltage	32 V
Diagnostics	defined in application

Signal input - PWMIN

Number of PWMIN	3
Frequency range	100 to 400 Hz
Minimum pulse width	250 us
Resolution	12 bits
Logic levels low high	<1 V >4 V
hysteresis	>250 mV
Input impedance	>1 Mohm in parallel with 10 nF
Maximum continuous voltage	32 V
Diagnostics	defined in application

Power driver - DOUT

Number of DOUT low-side	8 (configuration may reduce number)
Maximum load Single channel DOUT ABCD Combined DOUT EFGH Combined	300 mA 850 mA 850 mA
Leakage current in OFF state	<200 uA
Protection	over load, SCB, SCG
Diagnostics Open load, output OFF Over current threshold, output ON	> 50 Kohm @ VBAT = 9V, > 140 Kohm @ VBAT = 18V > 500 mA

CAN

Number of CAN buses	1
CAN specification	2.0A and 2.0B
CAN bus speed	250 kbit
Protection	SCB, SCG

Approvals

CE	2014/30/EU, EMC directive 2011/65/EU, ROHS 2
UKCA	EMC regulations 2016 ROHS regulations 2012

Appendix B

Error codes, messages and actions

If one of the following error is detected, a message will be presented with an error code on the module. In some cases, the module will turn off or at least shut down the outputs, to increase safety.

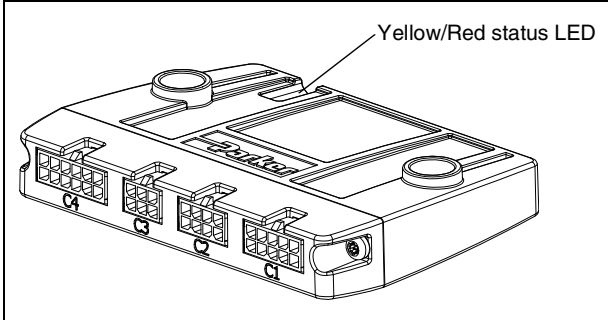

WARNING

Don't use the machine if an error message or error code is activated.

LED indicator showing different XC21 modes

Status	Flash (yellow)
Normal operation	

Error code	Error	Primary flash (red) Error category	Secondary flash (yellow) Error description
1:1	DOUT error (open load)		
1:3	VREF error		
2:1	VBAT warning		
2:2	Temperature warning		
3:1	CAN error/Timeout		
3:2	IdTag error		
3:4	CAN error (bus off)		
FE	Critical error		

Appendix C

Dimensioning of the IQAN-XC21

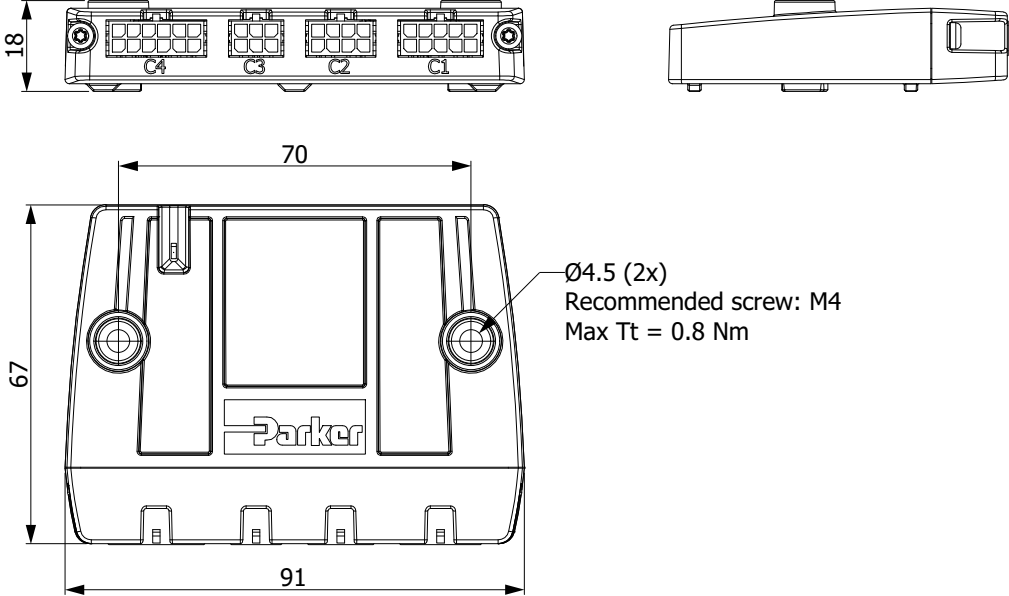

units=mm

For latest information visit our website www.iqan.com

Information in this instructionbook is subject to change without notice

Parker Hannifin
Mobile Systems Division
SE-435 35 Mölnlycke
Sweden
Tel +46 31 750 44 00
Fax +46 31 750 44 21
www.parker.com

Parker Hannifin
Electronic Controls Division
1651 N. Main Street
Morton, IL 61550
USA
Tel +1 309 266 2200
Fax +1 309 266 6674

Publ no MSG18-8410-IB/UK
Edition 2022-11-04

